

## REFERENCES

- Arfani, R. N., & Dewanta, A. S. (2018). Production Shifts and Upgrading in ASEAN Automotive Production Network: Case on Toyota-led Regional Value Chains. *The Indonesian Journal of Southeast Asian Studies*, 115-143.
- Berman, E., & Berman, D. (2011). *People Skills at Work*. Boca Raton: CRC Press.
- Bounfour, A. (2022). *Platforms and Artificial Intelligence: The Next Generation of Competences*. Berlin: Springer International Publishing.
- Eid, R. (2013). *Managing Customer Trust, Satisfaction, and Loyalty Through Information Communication Technologies*. Pennsylvania: IGI Global.
- Evers, N., Cunningham, J., & Hoholm, T. (2020). *Technology Entrepreneurship: Bringing Innovation to the Marketplace*. London: Macmillan Education.
- Flamholtz, G. E., & Randle, Y. (2015). *Growing Pains: Building Sustainably Successful Organizations*. New Jersey: Wiley.
- Frater, G. (2003). *Business and Communication Systems*. Oxford: Nelson Thornes Limited.
- Frei, F. X. (2008). The Four Things a Service Business Must Get Right. *Harvard Business Review*, 70-80.
- Jain, D., Mahajan, V., & Muller, E. (1995). An Approach for Determining Optimal Product Sampling for the Diffusion of a New Product. *Journal of Product Innovation Management*, 124-135.
- Jin, D. Y. (2019). *Globalization and Media in the Digital Platform Age*. London: Taylor & Francis.
- Jurriens, E., & Tapsell, R. (2017). *Digital Indonesia: Connectivity and Divergence*. Singapore: ISEAS Publishing.
- Kaufman, H.-R. (2014). *Handbook of Research on Managing and Influencing Consumer Behavior*. Pennsylvania: IGI Global.

- Kelley, D., & Brown, T. (2018). *An Introduction to Design Thinking*. California: Institute of Design Stanford.
- Kemenkominfo. (2022). *Pengguna Internet di Indonesia 63 Juta Orang*. Retrieved August 28, 2022, from [https://www.kominfo.go.id/index.php/content/detail/3415/Kominfo+%3A+Pengguna+Internet+di+Indonesia+63+Juta+Orang/0/berita\\_satker](https://www.kominfo.go.id/index.php/content/detail/3415/Kominfo+%3A+Pengguna+Internet+di+Indonesia+63+Juta+Orang/0/berita_satker)
- Kim, D. J., Ferrin, D. L., & Rao, R. (2015). A Trust-Based Consumer Decision-Making Model in Electronic Commerce: The Role of Trust, Perceived Risk, and Their Antecedents. *American Journal of Industrial and Business Management*, 544-564.
- Knapp, D. E. (1999). *The Brand Mindset: Five Essential Strategies for Building Brand Advantage Throughout Your Company*. New York: McGraw-Hill Education.
- Kot, S., & Dragon, P. (2015). Business Risk Management in International Corporations. *Procedia Economics and Finance*, 102-108.
- Kotler, & Pfoertsch. (2008). *B2B Brand Management*. New York: Springer Publisher.
- Kotler, P., & Armstrong, G. M. (2012). *Principles of Marketing*. New Jersey: Pearson Prentice Hall.
- Kotler, P., & Keller, K. (2012). *Marketing Management*. London: Pearson.
- Langerak, F. (2001). The Relationship between Customer and Supplier Perceptions of the Manufacturer's Market Orientation and Its Business Performance. *International Journal of Market Research*, 1-19.
- Liebana-Cabanillas, F., Ramos de Luna, I., Lladós-Masllorens, J., & Fito-Bertran, A. (2019). *Sharing Economy and the Impact of Collaborative Consumption*. Pennsylvania: IGI Global.
- Mattson, C., & Sorensen, C. (2019). *Product Development: Principles and Tools for Creating Desirable and Transferable Designs*. New York: Springer International Publishing.

- Meyer, C., & Schwager, A. (2007). Understanding customer experience. *Harvard Business Review*, 117-126.
- Moleong, L. (2005). *Metodologi Penelitian Kualitatif*. Bandung: PT. Remaja Rosdakarya.
- Montgomery, C. (1994). Corporate Diversification. *Journal of Economic Perspectives*, 163-178.
- Mullins, J. (2014). *The Customer-Funded Business Start, Finance, Or Grow Your Company with Your Customers' Cash*. New Jersey: Wiley.
- Osterwalder, A., & Pigneur, Y. (2012). *Business Model Generation*. Jakarta: Elex Media Komputindo.
- Perdomo, E., Lakshmi, G., Hernandez, J., Acosta, M., & Villarreal, R. (2022). *The Emerald Handbook of Challenge Based Learning*. Bradford: Emerald Publishing Limited.
- Quigley, J., Walls, L., Damirel, G., McCarthy, B. L., & Parsa, M. (2018). Supplier quality improvement: The value of information under uncertainty. *European Journal of Operational Research*, 932-947.
- Regis, R. (2008). *Strategic Human Resource Management and Development*. New Delhi: Excel Books.
- Rothschild, M. (2004). *Bionomics: Economy as Business Ecosystem*. Pennsylvania : Beard Books.
- Schallmo, D. R., & Tidd, J. (2021). *Digitalization: Approaches, Case Studies, and Tools for Strategy, Transformation and Implementation*. New York: Springer International Publishing.
- Schmidt, A. B. (2011). *Financial Markets and Trading: An Introduction to Market Microstructure and Trading Strategies*. New Jersey: Wiley.
- Schuh, G., Potente, T., Wesch-Potente, C., Weber, A., & Prote, J.-P. (2014). Collaboration Mechanisms to Increase Productivity in the Context of Industry 4.0. *Procedia CIRP*, 51-56.

- Shankaraniah, K. (2021). *Global Internet Users' Growth and To E-Commerce Markets*. Hongkong: Chartered Secretary.
- Shenoy, D., & Bhadbury, B. (1998). *Maintenance Resource Management: Adapting Materials Requirements Planning MRP*. Boca Raton: CRC Press.
- Subrahmaniyam, M. (2009). *Performance Management: Measure and Improve the Effectiveness of Your Employees*. New Delhi: Global India Publications Pvt. Limited.
- Thain, G., & Bradley, J. (2014). *FMCG: The Power of Fast-Moving Consumer Goods*. Sarasota: First Edition Design Publishing.
- Wang, W., & Marcus, A. (2019). *Design, User Experience, and Usability. Practice and Case Studies*. New York: Springer International Publishing.
- Wicks, A. C., Moriarty, B., & Harris, J. D. (2014). *Public Trust in Business*. Cambridge: Cambridge University Press.
- Wilson, K., Speare, N., Reese, S., & Heiman, M. (2002). *Successful Global Account Management: Key Strategies and Tools for Managing Global Customers*. London: Kogan Page.
- Zott, C., Amit, R., & Massa, L. (2011). The business model: Recent developments and future research. *Journal Management*, 1019-1042.

## **APPENDIX**

## LEMBAR PERSETUJUAN RESPONDENT

(Informed consent)

Saya yang bertandatangan dibawah ini :

Nama : *Andrianto*

No Telp : *0877.8538.3808*

Dengan ini menyatakan bersedia dan tidak keberatan menjadi responden dalam penelitian rencana business yang dilakukan mahasiswa Program studi Magister Manajemen Teknologi Universitas Presiden. Dimana judul penelitian PRODUCT DEVELOPMENT OF DIGITAL PLATFORM FOR INTEGRATED E-PROCUREMENT OF CUSTOMIZED COMPONENT PARTS.

Demikian pernyataan ini saya buat dengan sukarela tanpa paksaan dari pihak manapun dan kiranya dapat digunakan sebagaimana mestinya.

Cikarang, *17/12/22*

  
-----

## LEMBAR PERSETUJUAN RESPONDENT

(Informed consent)

Saya yang bertandatangan dibawah ini :

Nama : G. Priyanto Wibowo  
No Telp : 0852 1271 5003

Dengan ini menyatakan bersedia dan tidak keberatan menjadi responden dalam penelitian rencana business yang dilakukan mahasiswa Program studi Magister Manajemen Teknologi Universitas Presiden. Dimana judul penelitian PRODUCT DEVELOPMENT OF DIGITAL PLATFORM FOR INTEGRATED E-PROCUREMENT OF CUSTOMIZED COMPONENT PARTS.

Demikian pernyataan ini saya buat dengan sukarela tanpa paksaan dari pihak manapun dan kiranya dapat digunakan sebagaimana mestinya.

Cikarang,

18/12 '22  
  
.....

**LEMBAR PERSETUJUAN RESPONDENT**

(Informed Consent)

Saya yang bertandatangan di bawah ini:

Nama : SUSILAWATI

No. Telpon : 0957 29154915

Dengan ini menyatakan bersedia dan tidak keberatan menjadi responden dalam penelitian rencana yang dilakukan mahasiswa Program Studi Magister Manajemen Teknologi Universitas Presiden. Di mana judul penelitian PRODUCT DEVELOPMENT OF DIGITAL PLATFORM FOR INTEGRATED E-PROCUREMENT OF CUSTOMIZED COMPONENT PARTS.

Demikian pernyataan ini saya buat dengan sukarela tanpa paksaan dari pihak manapun dan kiranya dapat digunakan sebagaimana mestinya.

Subang, 17 Desember 2022





## LEMBAR PERSETUJUAN RESPONDENT

(Informed consent)

Saya yang bertandatangan dibawah ini :

Nama : Bambang Triyoro

No Telp : 0882 9862 9551

Dengan ini menyatakan bersedia dan tidak keberatan menjadi responden dalam penelitian rencana business yang dilakukan mahasiswa Program studi Magister Manajemen Teknologi Universitas Presiden. Dimana judul penelitian PRODUCT DEVELOPMENT OF DIGITAL PLATFORM FOR INTEGRATED E-PROCUREMENT OF CUSTOMIZED COMPONENT PARTS.

Demikian pernyataan ini saya buat dengan sukarela tanpa paksaan dari pihak manapun dan kiranya dapat digunakan sebagaimana mestinya.

Bekasi, 3 Jan 2023

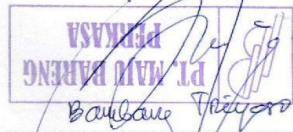
  
PT. MAJU BARENG  
Bambang Triyoro

## LEMBAR PERSETUJUAN RESPONDENT

(Informed consent)

Saya yang bertandatangan dibawah ini :

Nama : HURSAIM

No Telp : 0857 8245 2761

Dengan ini menyatakan bersedia dan tidak keberatan menjadi responden dalam penelitian rencana business yang dilakukan mahasiswa Program studi Magister Manajemen Teknologi Universitas Presiden. Dimana judul penelitian PRODUCT DEVELOPMENT OF DIGITAL PLATFORM FOR INTEGRATED E-PROCUREMENT OF CUSTOMIZED COMPONENT PARTS.

Demikian pernyataan ini saya buat dengan sukarela tanpa paksaan dari pihak manapun dan kiranya dapat digunakan sebagaimana mestinya.

Cikarang,

A rectangular stamp with the letters 'HMK' inside, with a handwritten signature scribble over it. Below the stamp is a dotted line for a signature.

## LEMBAR PERSETUJUAN RESPONDENT

(Informed consent)

Saya yang bertandatangan dibawah ini :

Nama : HUGROHO A.P

No Telp :

Dengan ini menyatakan bersedia dan tidak keberatan menjadi responden dalam penelitian rencana business yang dilakukan mahasiswa Program studi Magister Manajemen Teknologi Universitas Presiden. Dimana judul penelitian PRODUCT DEVELOPMENT OF DIGITAL PLATFORM FOR INTEGRATED E-PROCUREMENT OF CUSTOMIZED COMPONENT PARTS.

Demikian pernyataan ini saya buat dengan sukarela tanpa paksaan dari pihak manapun dan kiranya dapat digunakan sebagaimana mestinya.

Cikarang,



.....NUGROHO A.P.....

## LEMBAR PERSETUJUAN RESPONDENT

(Informed consent)

Saya yang bertandatangan dibawah ini :

Nama : Ledwan Salam

No Telp : 08129544870

Dengan ini menyatakan bersedia dan tidak keberatan menjadi responden dalam penelitian rencana business yang dilakukan mahasiswa Program studi Magister Manajemen Teknologi Universitas Presiden. Dimana judul penelitian PRODUCT DEVELOPMENT OF DIGITAL PLATFORM FOR INTEGRATED E-PROCUREMENT OF CUSTOMIZED COMPONENT PARTS.

Demikian pernyataan ini saya buat dengan sukarela tanpa paksaan dari pihak manapun dan kiranya dapat digunakan sebagaimana mestinya.

Cikampek, 17/10/2022



.....  
Ledwan Salam

## LEMBAR PERSETUJUAN RESPONDENT

(Informed consent)

Saya yang bertandatangan dibawah ini :

Nama : RIZAL FADILAH

No Telp : 0857 - 2776 - 7459

Dengan ini menyatakan bersedia dan tidak keberatan menjadi responden dalam penelitian rencana business yang dilakukan mahasiswa Program studi Magister Manajemen Teknologi Universitas Presiden. Dimana judul penelitian PRODUCT DEVELOPMENT OF DIGITAL PLATFORM FOR INTEGRATED E-PROCUREMENT OF CUSTOMIZED COMPONENT PARTS.

Demikian pernyataan ini saya buat dengan sukarela tanpa paksaan dari pihak manapun dan kiranya dapat digunakan sebagaimana mestinya.

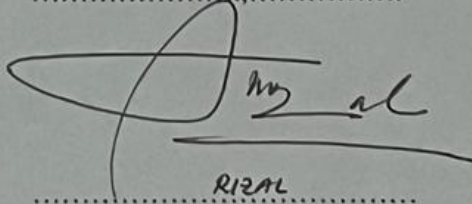
CIKARANG 4 OKTOBER 2022  
.....  
  
.....  
RIZAL

## LEMBAR PERSETUJUAN RESPONDENT

(Informed consent)

Saya yang bertandatangan dibawah ini :

Nama : *Bangun Upayo*

No Telp : *081311492805*

Dengan ini menyatakan bersedia dan tidak keberatan menjadi responden dalam penelitian rencana business yang dilakukan mahasiswa Program studi Magister Manajemen Teknologi Universitas Presiden. Dimana judul penelitian PRODUCT DEVELOPMENT OF DIGITAL PLATFORM FOR INTEGRATED E-PROCUREMENT OF CUSTOMIZED COMPONENT PARTS.

Demikian pernyataan ini saya buat dengan sukarela tanpa paksaan dari pihak manapun dan kiranya dapat digunakan sebagaimana mestinya.

Cikampek, *24 Januari* 2023

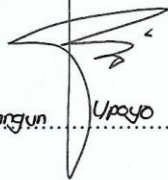
  
*Bangun Upayo*



## LEMBAR PERSETUJUAN RESPONDENT

(Informed consent)

Saya yang bertandatangan dibawah ini :

*( I hereby signed )*

Nama *( Name )* : Jini

No Telp *( Phone Number )* : +886 918 095 403

Dengan ini menyatakan bersedia dan tidak keberatan menjadi responden dalam penelitian rencana business yang dilakukan mahasiswa Program studi Magister Manajemen Teknologi Universitas Presiden. Dimana judul penelitian PRODUCT DEVELOPMENT OF DIGITAL PLATFORM FOR INTEGRATED E-PROCUREMENT OF CUSTOMIZED COMPONENT PARTS.

*I hereby declare that I am willing and have no objection to being a respondent in business plan research conducted by students of the Technology Management Masters Study Program at President University. Where is the research title PRODUCT DEVELOPMENT OF DIGITAL PLATFORM FOR INTEGRATED E-PROCUREMENT OF CUSTOMIZED COMPONENT PARTS.*

Demikian pernyataan ini saya buat dengan sukarela tanpa paksaan dari pihak manapun dan kiranya dapat digunakan sebagaimana mestinya.

*I make this statement voluntarily without coercion from any party and I hope it can be used properly.*

Taiwan, 12 December 2022



( Jini )

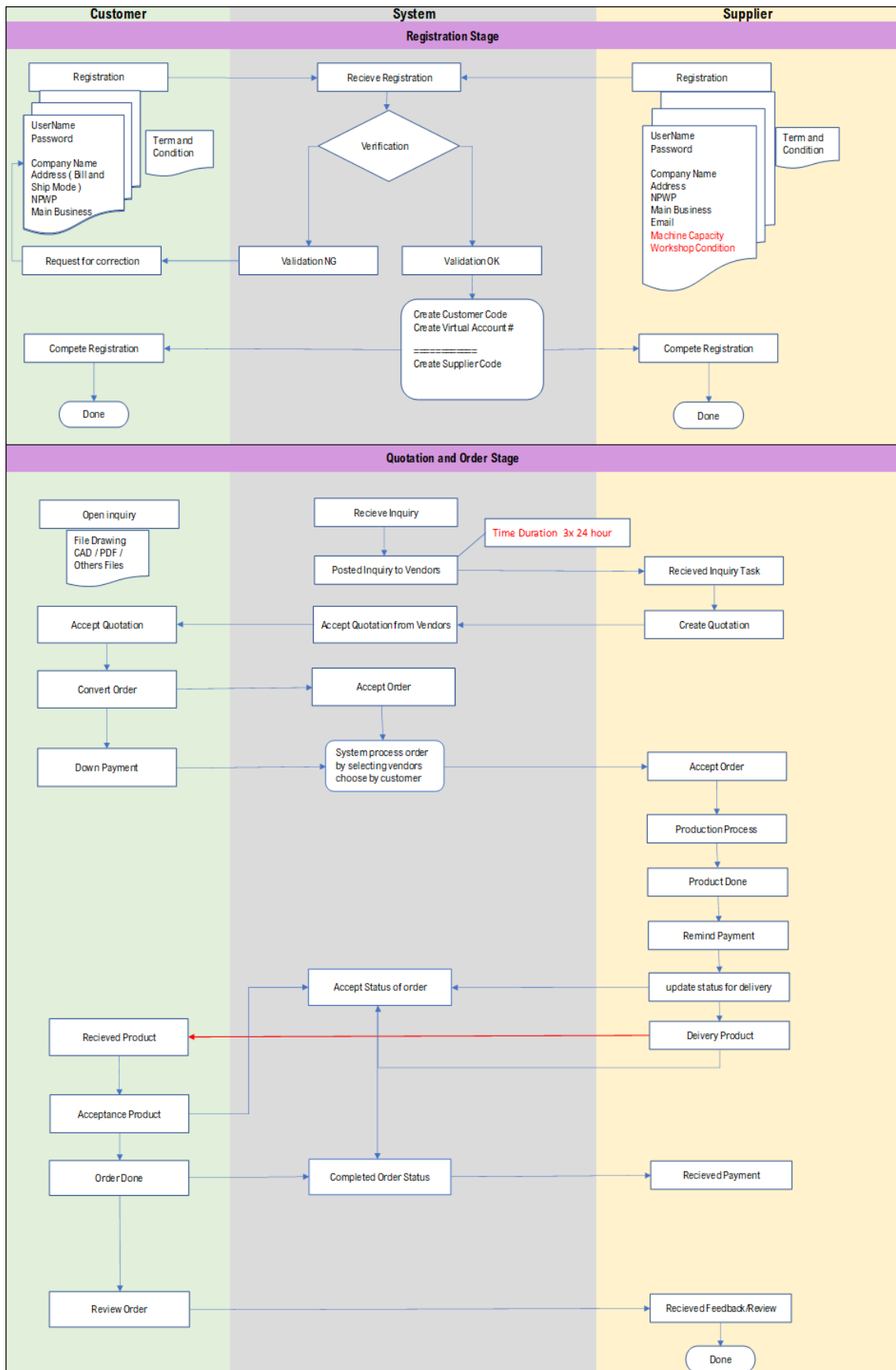



**Workshop PT. Galaksi Teknologi Mandiri**



**Workshop PT. Wim Toolsindo**



**Workshop PT. Manjava Sejahtera Cemerlang**



**Workshop CV. Tambora**





**Workshop CV. Hansamu Wiyasa Karya**

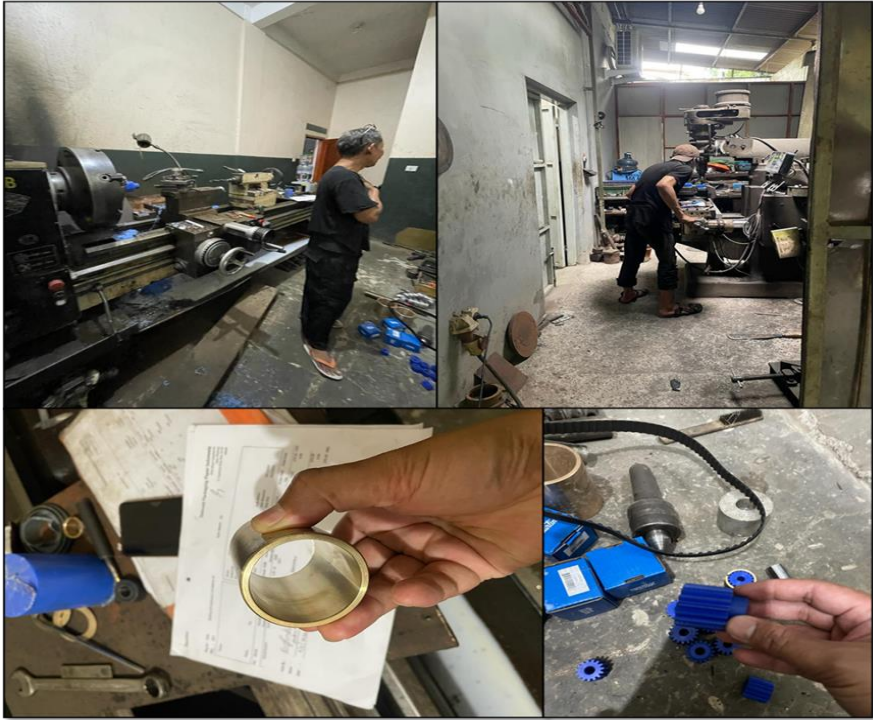

**Workshop PT. Sugimoto Presisi Teknologi**



**Workshop CV. Maru Mulya Perkasa**



**Workshop PT. Maju Bareng Perkasa**

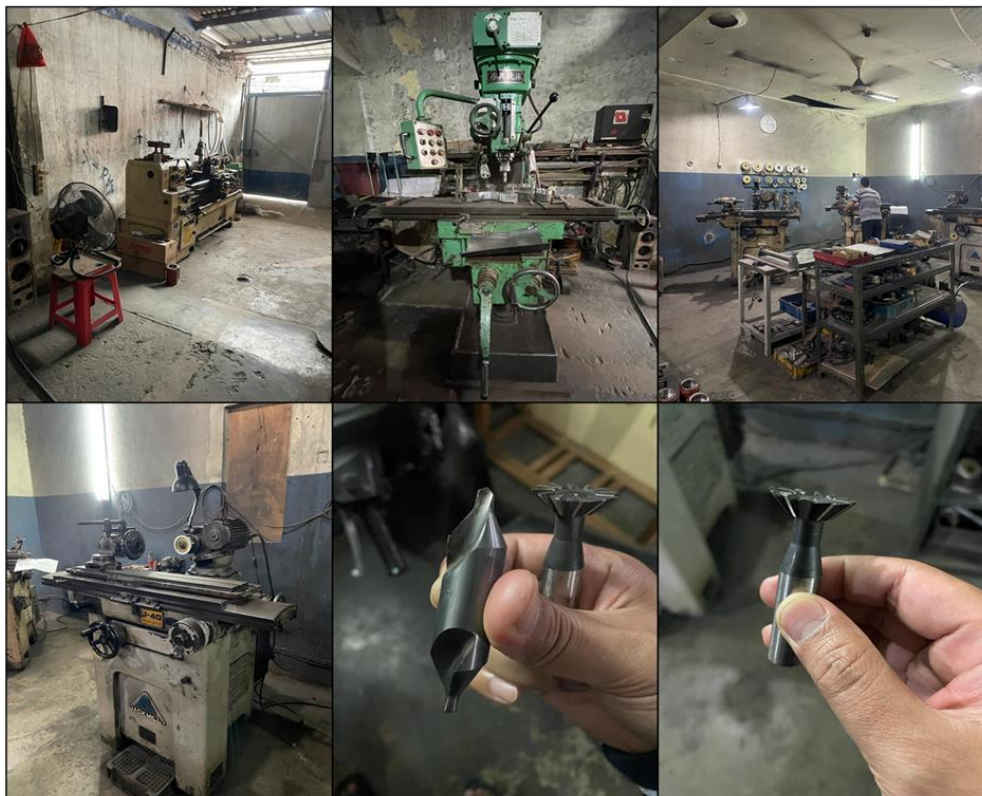



**Workshop LINCO Precision Industrial Co.,Ltd.**



**Workshop Politeknik Negeri Subang**



SYM	DATE	REVISION	SIGNED	CHECKED	APPROVED
△	B	C	D		
△					

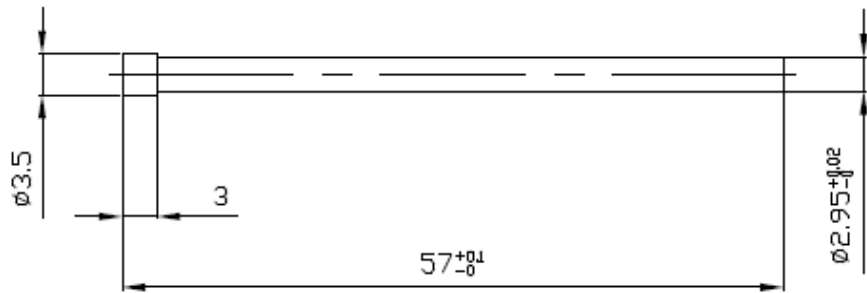

~	~	1	SKD11	General Tolerance	~	~
CODE NO	POS NO	QTY	MATERIAL	- 6=0.14	PROCESS	REMARK
SCALE	2:1	FINISH	1.6/√	6- 30=0.22	NAME	STRAIGHT_PUNCH
DESIGNED	DRAWN	CHECKED	APPROVED	30-120=0.35		
MARIA	MARIA			120- =0.50	NO	~
19012023	19012023				3rd Angle System	Unit = m m A4

SYM	DATE	REVISION	SIGNED	CHECKED	APPROVED
△					
△					

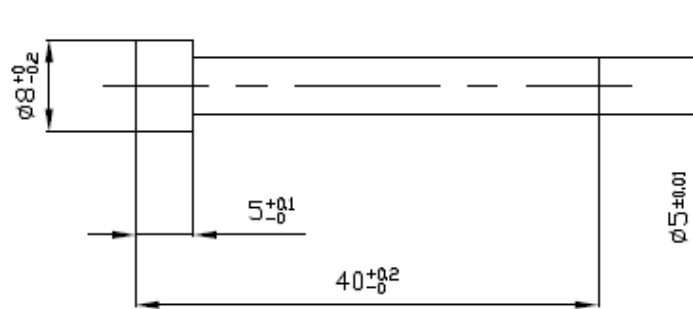

~	~	1	SKD11	General Tolerance	~	~
CODE NO	POS NO	QTY	MATERIAL	- 6=0.14	PROCESS	REMARK
SCALE	2:1	FINISH	1.6	HRC	60~63	STRAIGHT_PUNCH
DESIGNED	DRAWN	CHECKED	APPROVED	6- 30=0.22		
MARIA	MARIA			30-120=0.35		~
19012023	19012023			120- =0.50		~
					3rd Angle System	Unit = m m A4

SYM	DATE	REVISION	SIGNED	CHECKED	APPROVED
△					
△					

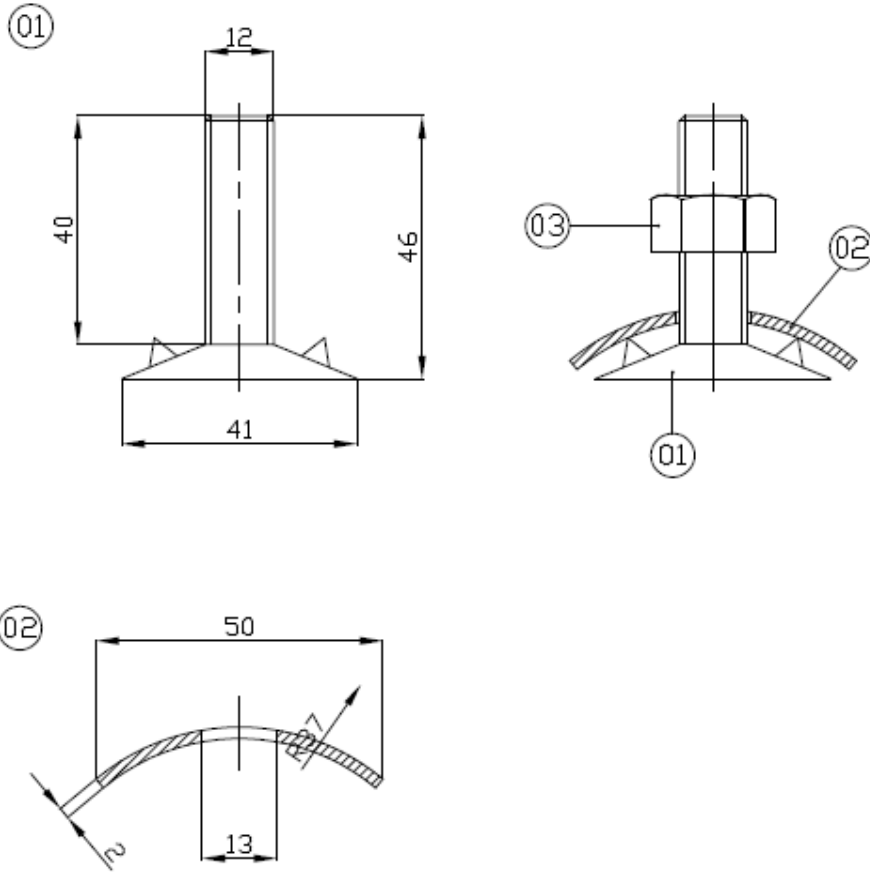

4	NYLON LOCK NUT	1	STD	-	-
3	NUT	1	STD	-	-
2	RING	1	MS	-	GALV
1	BAUT	1	MS	-	GALV
NO	NAMA	QTY	MAT	HARD	KET

~		~		1	~		General Tolerance - 6=0.14 6- 30=0.22 30-120=0.35 120- =0.50	~		~	
CODE NO	POS NO	QTY	MATERIAL		PROCESS			REMARK			
SCALE	1:1	FINISH	1.6	HRC	~		NO	~		~	
DESIGNED	DRAWN		CHECKED		APPROVED			~		~	
MARIA	MARIA							~		~	
19012023	19012023							3rd Angle System		Unit = m m	A4